



Cruzber S.A., ES-A14018311
P.I. Las Salinas II, E-14960 Rute
www.cruzber.com

- (E)** Instrucción de montaje
¡Leer primero!
- (GB)** Assembly instructions
Read first!
- (F)** Instruction de montage
Lire en premier!
- (D)** Montageanleitung
Zuerst lesen!
- (PT)** Instruções de montagem
Ler primeiro!
- (PL)** Instrukcja montażu
Najpierw przeczytaj!
- (CZ)** Montážní návod
Čtěte pozorně!
- (HU)** Szerelési Utasítás
Először olvassd el!
- (RO)** Instrucțiuni de montaj
Întai citiți!
- (HR)** Detaljne upute
Prvo pročitati!
- (GR)** Διαβάστε προσεκτικά τις
Οδηγίες Συναρμολόγησης!
- (TR)** Öncelikli montaj:
Talimatlarını okuyunuz!
- (RU)** Инструкции по монтажу
Сначала прочитайте!
- (IT)** Istruzioni di montaggio
Leggere per primo!
- (NL)** Montagehandleiding
Eerst lezen!
- (SLO)** Navodila za sestavljanje
Preberite!

- Barras de acero
- Steel bars
- Barres d'acier
- Stahldachträger
- Barras d'aço
- Belki stalowe
- Ocelové střešní nosiče
- Acél rudak
- Čelične šipke
- Bare din otel
- Μπάρες Σιδερέ
- Çelik barlar
- Стальные поперечины
- Barre d'acciaio
- Stalen dakdragers
- Jeklene prečke

Código Code Code Kode	921- 00x				
Lv 7 2015 - r13					
Modelo Model Modèle Modell	OT 30x20x1,2 G				
Lote Lot Lot Lot	<table style="display: inline-table; border: none;"> <tr><td style="border: 1px solid black; width: 15px; height: 15px;"></td></tr> <tr><td style="border: 1px solid black; width: 15px; height: 15px;"></td></tr> <tr><td style="border: 1px solid black; width: 15px; height: 15px;"></td></tr> <tr><td style="border: 1px solid black; width: 15px; height: 15px;"></td></tr> </table>				
Peso Weight Poids Gewicht	<table style="display: inline-table; border: none;"> <tr><td style="border: 1px solid black; width: 15px; height: 15px;"></td></tr> <tr><td style="border: 1px solid black; width: 15px; height: 15px;"></td></tr> <tr><td style="border: 1px solid black; width: 15px; height: 15px;"></td></tr> <tr><td style="border: 1px solid black; width: 15px; height: 15px;"></td></tr> </table>				
<table style="display: inline-table; border: none;"> <tr><td>Kit A: Max. 50kg</td></tr> <tr><td>Kit B: Max. 60kg</td></tr> </table>		Kit A: Max. 50kg	Kit B: Max. 60kg		
Kit A: Max. 50kg					
Kit B: Max. 60kg					
Código Homologación ECE R 26.03 R 26.03 ECE Type Approval Number E9-26R-03.3015					

	1°	
	2°	

- (E)** Contenido embalaje: ¡Verificar!
- (GB)** Package content: Check!
- (F)** Contenu d'emballage: Vérifier!
- (D)** Packungsinhalt: Überprüfen!
- (PT)** Contéudo embalagem: Verificar!
- (PL)** Zawartość opakowania: sprawdzić!
- (CZ)** Obsah balení: Zkontrolujte!
- (HU)** Csomag tartalma: Ellenőrizd!
- (RO)** Pachetul contine: Verificati!
- (HR)** Sadržaj paketa: Provjeri!
- (GR)** ΕΛΕΓΞΤΕ ΤΟ ΠΕΡΙΕΧΟΜΕΝΟ: ΤΟΥ ΠΑΚΕΤΟΥ!
- (TR)** Paket içeriğini: Kontrol ediniz!
- (RU)** Содержание упаковки: Проверьте!
- (IT)** Contenuto della confezione: Controllare!
- (NL)** Pakket inhoud: Controleer!
- (SLO)** Vsebina paketa: Preverite!

x 1	x 1	x 2	x 2

Código Code		↔			Lote Lot
921-000	OT-105 (823-203)	105 cm	81,5 cm (825-204)	3,64 kg	02/07
921-001	OT-115 (823-213)	115 cm	95 cm (825-214)	3,96 kg	02/07
921-004	OT-140 (823-343)	140 cm	108 cm (825-222)	5,70 kg	01/14

Código
Code
Code
Kode

921-00x

Lv 7 2015 - r 13

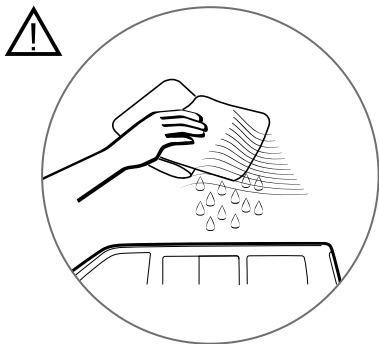

**! Importante!
! Important!
! Wichtig!**

- E** Estas barras tienen que usarse con Kits de fijación Cruz!
- GB** Bars must be used with Cruz fixation Kits!
- F** Les barres devront être utilisées avec les Kits de fixation Cruz!
- D** Die Dachlsträger nur mit Cruz Stützfuß-Kits befestigen!
- PT** As barras devem ser utilizadas com os Kits de fixação Cruz!
- PL** Belki muszą być stosowane z elementó w mocujęcymi firmy Cruz!
- CZ** Tento nosič musí být používán s fixačním kitem Cruz!
- HU** A rudakat csak Cruz rögzítő készlettel szabad használni!
- RO** Barele trebuie utilizate cu Kit-uri de fixare Cruz!
- HR** Šipke moraju biti korištene sa Cruz kitovima za montažu!
- GR** Το αξεσουάρ αυτό θα πρέπει να χρησιμοποιείται αποκλειστικά στα συστήματα μπαρών της Cruz!
- TR** Bu barlar mutlak Cruz montaj kiti!
- RU** Поперечины должны быть использованы со специальным крепежным комплектом Cruz!
- IT** Questa bare deve essere utilizzato solo con il kit di fissaggio Cruz!
- NL** Dakdragers moeten worden gebruikt in combinatie met de bevestigingssets van Cruz!

1

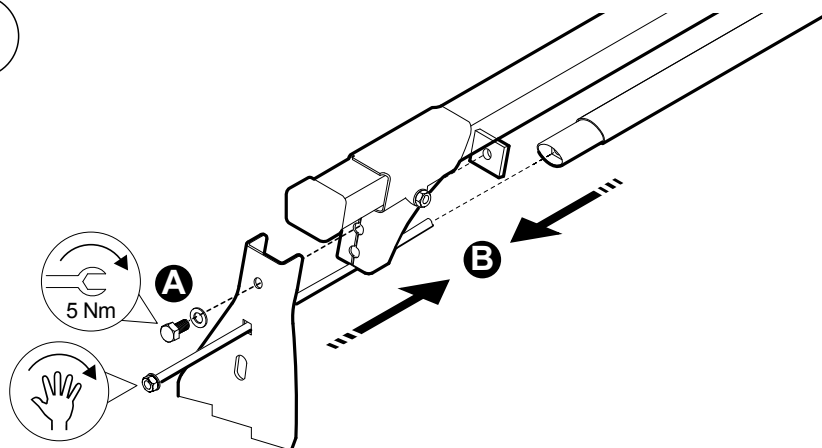

2



3

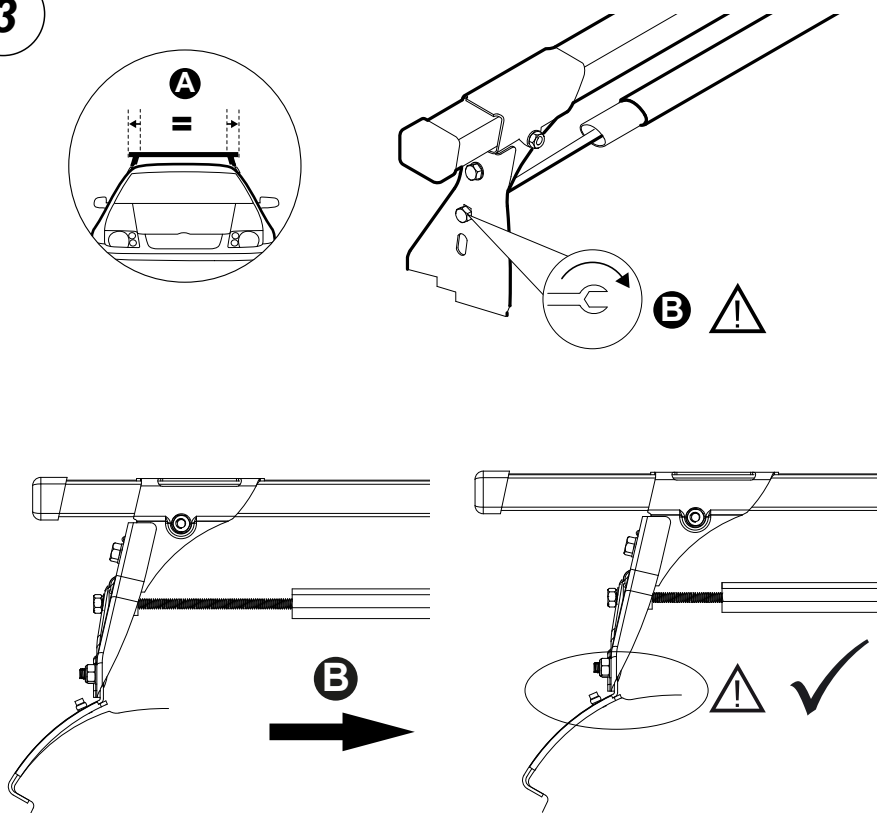

4

